

Opto-Electronic Oscillator in the mm-W range for 5G Wireless and Mobile Networks: Design Challenges and Possible Solutions

Mehmet Alp Ilgaz¹, Bostjan Batagelj^{1,2}, *Member, IEEE*

¹University of Ljubljana, Faculty of Electrical Engineering,
Trzaska 25, 1000 Ljubljana, Slovenia

²Centre of Excellence for Biosensors, Instrumentation and Process Control, Tovarniska 26, 5270 Ajdovscina, Slovenia
Tel: +386 1 4768 400, e-mail: Mehmet.Ilgaz@fe.uni-lj.si

Abstract – The forthcoming fifth generation (5G) of wireless and mobile technology is expected to use high-spectral-purity signals in the millimeter-wave (mm-W) range. The opto-electronic oscillator (OEO) is a well-known, low-phase-noise oscillator that is capable of generating high-frequency signals in the radio or microwave range, and can also be used in the mm-W range. In order to meet the high-spectral-purity demand of 5G wireless and mobile technology, the OEO is one of the most promising solutions for implementing the mm-W generation required in base-stations. Even though the OEO brings some advantages, there are also some challenges, which need to be fixed in order to produce a low-noise signal in the mm-W range efficiently. In this paper, information about OEO design issues, problems and possible solutions expected in mm-W applications will be explained and discussed.

Keywords – 5G wireless and mobile networks, low phase noise, single-loop opto-electronic oscillator, frequency drift, multi-mode operation, chromatic dispersion, Rayleigh scattering

I. INTRODUCTION

The fifth-generation (5G) technology that will provide 1 Gbit/s transmission rates with a coverage of energy-efficient micro/pico/femto cells and air interfaces using mm waves (mm-Ws) is currently being extensively discussed in the wireless and mobile research field. Due to the high attenuation of mm-Ws, the short-range communications in 5G wireless and mobile networks will have a large number of cells with limited cell sizes. The frequency range of the mm-W is defined as being between 30 GHz and 300 GHz, where the ultra-broadband spectrum is available. The use of mm-W ultra-broadband transmission will only enable a capacity increase if the advanced modulation format and/or Orthogonal Frequency Division Multiplexing (OFDM) are used. **The transmission capacity of the mm-W link will stay in the range of today's radio networks if the phase of the mm-W oscillator stays in the same range.** A suitable candidate with low-phase-noise characteristics is the opto-electronic oscillator (OEO) [1].

The OEO is a well-known device that can produce high-quality signals in the radio-frequency (RF), microwave (u-W) and mm-W ranges [2]. The OEO is surprisingly different from other oscillators in that the phase noise does not depend on the operating frequency [3]. This means that there is no direct relationship between the phase noise and the frequency, like

other resonators such as the air-dielectric resonator, crystal resonator, quartz resonator or sapphire resonator. The reason for this positive attribute is that the OEO has a long optical delay line for its resonator. Optical glass-fiber is used as an optical delay line because it has a low loss characteristic (0.2 dB/km) [4]. A long delay line acts as a resonator with a high quality (Q) factor. The Q factor is based on the length of the delay line. This means that if we increase the length of the delay line we can increase the Q factor of the OEO. With this advantage, the phase noise of the OEO can be decreased.

Fig. 1 shows a typical configuration for a single-loop OEO, which consists of optical, electrical and opto-electronic components. The part where the optical signal is transmitted from laser to photodetector is called the optical path (shown in blue colour in the Fig. 1). The laser, which is at the beginning of the optical path, must be externally modulated by an electrical signal in order to produce high-frequency oscillations. For the external modulation, a Mach-Zehnder modulator (MZM) [5] or an electro-absorption modulator [6] is frequently used. The electrical path extends from photodetector where the optical signal is converted to electrical signal up to the end of feedback loop (shown in black colour). For filtering purposes, an optical and/or electrical filter should be implemented in the oscillator loop. In order to compensate for the loss of the oscillator loop, an optical and/or microwave amplifier can be used. At the end of the optical path the optical-to-electrical conversion is provided by a photodiode. A fiber spool, which represents the long delay line, is used to provide a connection between the laser and the photodiode. One of the advantages of the OEO is that both the electrical and optical outputs can be obtained from the OEO.

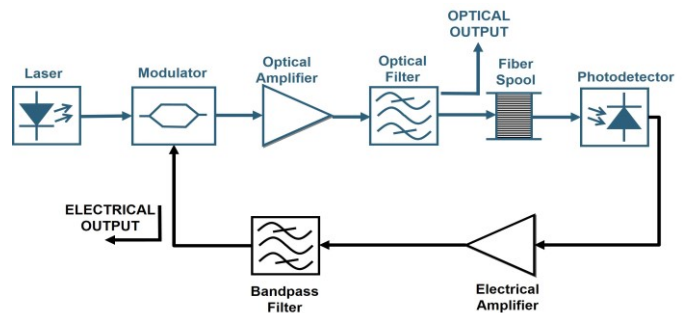

Figure 1: Schematic of a single-loop OEO [1]. In the OEO, the optical filter, optical amplifier and/or electrical amplifier and filter can be placed in the loop.

To implement a high spectral efficiency signal in the mm-W range for 5G wireless and mobile networks [7-8], it is believed that the OEO can play a key role. We propose simplifying the base-stations, and in this way make the 5G wireless and mobile network cost efficient [1] by removing the local oscillators from the base-stations and placing the OEO in the central station, from where it can feed a large number of base-stations and thereby divide the costs of the OEO signal generation between many base-stations. In addition, by locating the OEO in the central station of a controlled environment, we can easily control the oscillator and stabilize it more efficiently. This brings a useful advantage when using the mm-W range in 5G wireless and mobile networks, compared to current wireless access technologies. This integrated system will be designed and implemented at 39 GHz. The main aim of this system is to provide one oscillator signal to a large number of base stations with as much as high data bit rate and low latency. In the next section we will describe and discuss the possible problems and solutions of the implementation of the OEO in 5G mobile and wireless networks. The configuration of the OEO in 5G mobile and wireless networks that will be implemented is shown in Fig. 2.

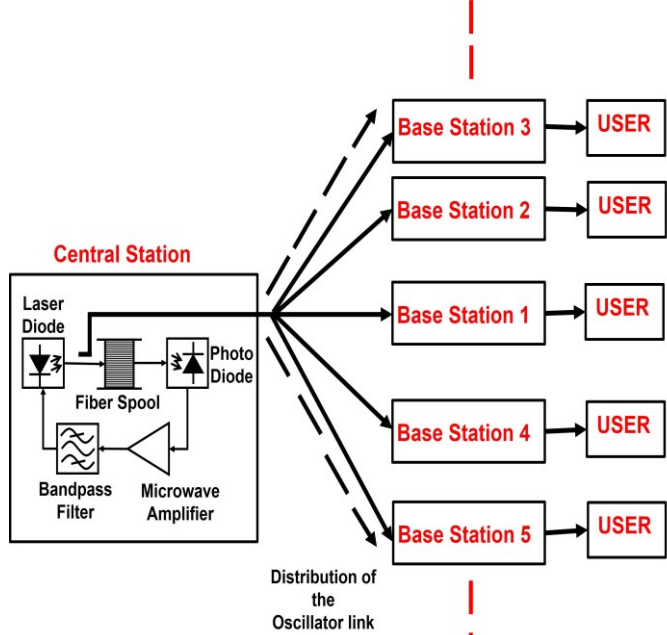

Figure 2: Main Idea of the implementation of the OEO in the 5G Mobile and Wireless Networks [1]. The low phase oscillator signal will be distributed to the base stations from the central station via one optical link. The number of base stations which benefit the oscillator line depends on several parameters of the OEO and the conditions of central station.

With this idea, which is explained in details in [1], we can simplify the base stations of the 5G wireless and mobile networks. One of the main advantage of using the OEO in central station that we can distribute one oscillator signal to plenty of base stations. This distribution depends on several parameters that will be explained in the second section. In addition, it is easier to stabilize the OEO if we place it in the central station. It will work in the temperature-controlled environment.

II. EXPECTED DESIGN CHALLENGES FOR THE OEO IN THE MILLIMETER WAVE RANGE

Even though a low-phase-noise OEO has some advantages from the system point of view for 5G wireless and mobile networks, some design problems need to be considered as well. This can be separated into four sections. These are the frequency drift, the multi-mode operation, the chromatic dispersion effect and the Rayleigh scattering. The OEO should be designed according to these issues so that it can work efficiently in the mm-W range. Fig. 3 shows these problems in a single-loop OEO. The phase noise of the OEO generally depends on the Laser Relative Intensity Noise (RIN), shot noise, thermal noise and amplifier noise. In addition, Rayleigh scattering and the modulation technique can contribute to the phase noise floor of the OEO.

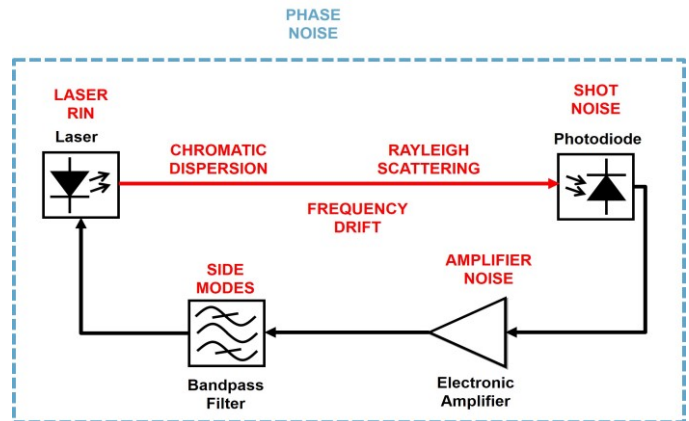

Figure 3: Main problems of the single-loop OEO were specified for the components [9].

Frequency Drift

One of the main issues with the OEO is its long-term stability. Long-term stability affects the phase noise and the frequency drift of the OEO which can cause a problem to produce high data bit rate is required by 5G wireless and mobile networks. This problem comes mainly from the dependency of the optical fiber's temperature coefficient. The instability of the temperature over the optical fiber can cause a change in the fiber's refractive index and frequency drift, which means there is a change of refractive index and the length of the optical delay line is changing. This is an unwanted effect of the optical fiber and can be a very limiting factor in many interferometric, optical loops or synchronization applications.

Side Modes

The OEO generates the signal in the fundamental mode and numerous side modes due to the nature of the multi-mode oscillation condition. Side modes also affects the phase noise of the OEO which can cause a problem to produce high data bit rate is required by 5G wireless and mobile networks. These side modes should be suppressed and completely eliminated in an ideal case. In order to achieve a suppression, an optical or electrical filter can be placed in the OEO's loop. Due to the

non-ideal behavior of the filters, side modes cannot generally be eliminated completely but they are only attenuated. Attenuation of the side modes depends on the Q-factor of the filter. In addition, side modes are affected by the flicker noise [10]. In order to strongly attenuate the oscillator side modes, a filter with a very high Q factor (around 10,000–15,000) is required. A very high Q factor filter, the characteristic of which is not affected by any temperature influence, is not easy to find on the market and very tricky to produce.

Chromatic Dispersion

Chromatic dispersion (CD) is a phenomenon that affects the performance of analog intensity-modulated optical links, and since an analog optical link is part of the OEO, chromatic dispersion also affects the performance of the OEO. This effect is reflected in a power degradation in the link due to the dispersion of the optical fiber. This means that chromatic dispersion can cause a power attenuation and phase shifts, and limit the data-transmission speed of the signal transmission over the optical link [11]. This is also one of the important parameters of the 5G wireless and mobile networks. Fig. 4 shows the effect of chromatic dispersion on the sidebands of the signal.

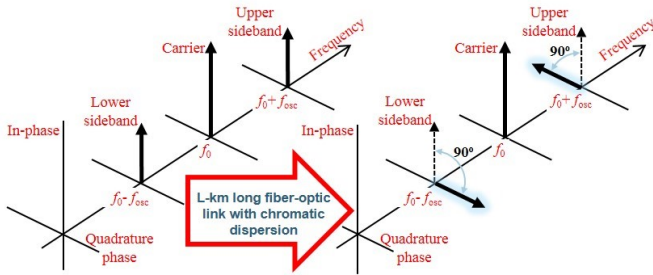

Figure 4: Spectrum of intensity-modulated signal at the fiber input and after L km of fiber. Chromatic dispersion changes the phase relationship between the optical carrier and the upper and lower sidebands [7].

The power penalty of the electrical signal due to fiber chromatic dispersion and fiber attenuation can be described [12-13] as;

$$P_{\text{osc}}(L, f_{\text{osc}}) \propto 20 \log \left(\cos \left(\frac{\pi L D_{\text{oc}}}{c_0} (\lambda_{\text{oc}} f_{\text{osc}})^2 \right) \right) - 2\alpha L \quad (1)$$

where, L is the optical fiber length, c_0 is the speed of light in free space, D_{oc} is the fiber-dispersion coefficient for the wavelength of the optical carrier, λ_{oc} is the optical carrier wavelength, f_{osc} is the oscillator frequency and α is the optical loss. From the equation 1, interferometric effects among the sidebands can cause the maximum and the minimum in the attenuation of the transmitted signals. In the case when the phase delay between the sidebands at the end of the fiber line is 180° , the destructive mixing on the PD will negate the entire oscillator signal. Fig. 5 shows the experimental work how the CD can cause a power penalty on the optical link with different lengths.

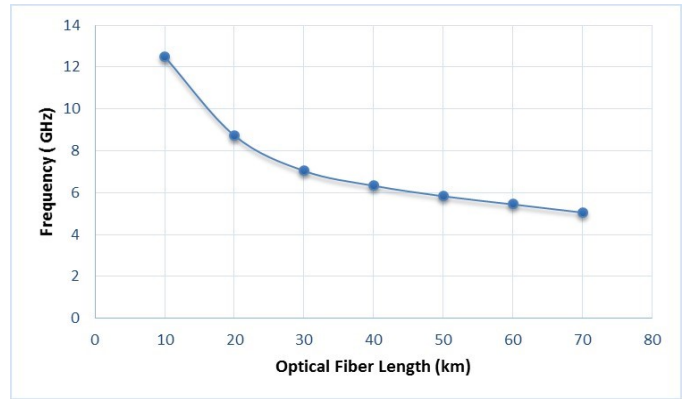

Figure 5: The measurement results of 3-dB power penalty of the analog optical link.

Rayleigh scattering

Rayleigh scattering, which occurs in the optical fiber, is the main reason for the loss of optical signal for the 1550-nm wavelength. In addition to this attenuation effect, Rayleigh scattering also induces the phase noise in the analog optical link, which is part of the OEO, as was already been mentioned in [14]. The contribution of the phase noise in the mm-W can decrease producing high bit data rate in the 5G mobile and wireless networks. According to [14] there is no quantitative method to describe the amplitude-to-phase conversion, but it has been found that Rayleigh scattering increases the RIN in the OEO. Rayleigh scattering can also cause a frequency shift in the oscillator's frequency. Generally, the scattered light in the optical fiber is converted to the phase noise and an increase in the total phase noise of the OEO. In [15] there is an experiment conducted to show that if there is a longer delay line in the OEO of more than 5 km, a double Rayleigh scattering is the dominant effect to increase the phase noise.

III. POSSIBLE METHODS TO OVERCOME THE PROBLEMS

As mentioned in the previous sections, the OEO has some critical challenges that should be sorted out. Now with this section we would like to give some possible solutions which were invented to avoid effects of each specific problem.

Frequency Drift

For frequency drift, one of the most effective solutions is the temperature stabilization of the optical fiber. This can be achieved by designing a stabilization system with lumped elements (such as a thermoelectric cooler). Since the temperature stabilization of the optical fiber is not sufficiently well fixed, an additional feedback-control loop can be used. With this method [16], there is a frequency discriminator with a PI controller and a wavelength control circuit added to the single-loop OEO. A feedback control loop fixes the group delay of the OEO, which means making the frequency constant. With this method, 0.05 ppm/K was obtained. The presented method has no effect on the phase noise. The drawback of the presented method for frequency stabilization

with the laser wavelength shift based on a temperature feedback loop is the limited range of compensation, but this can be accomplished with fiber temperature compensation, which provides a coarse adjustment and ensures that the laser temperature is always in the middle of the feedback regulation area.

Side Modes

In order to destroy the spurious modes coming from the oscillation, there have been plenty of methods implemented in the literature. One of the main purposes of these methods is to increase the Q factor of the electrical filter to suppress the side modes. To find a filter with a high Q factor, the characteristic of which will not drift with the temperature, is practically almost impossible. When using an optical filter (finesse etalon) [17], there are no visible side modes observed, but the optical filter also has a temperature influence and is quite an expensive component. Implementing one or more optical delay lines is another possible solution to suppress the side modes. This configuration is referred to as a dual-loop OEO [18] (if there is one more optical delay line added) or multi-loop OEO [19] (if the added optical delay line is more than one, such as two). The disadvantage of this method is that it increases the amount of component used in the OEO. It seems that practically the best example for implementation is to use an electrical bandpass filter where temperature stabilization of the filter is required. Recently, two methods for the suppression of the side modes are reported [20-21]. One of the methods is using the OEO with a quality multiplier [20]. In this method, the author was trying to decrease the loop bandwidth of the OEO. Because of the narrower bandwidth there are more suppressed side modes. With this method, an electrical circuit is added to the bandpass filter to increase the Q factor of the filter (so they obtained a narrower filter). They obtained a 20-dB improvement in the Side Mode Suppression Ratio (SMSR). Another method is called additional phase modulation [21]. With this method an electronically controlled phase shifter (ECPS) and SMSR booster are added in the OEO's loop. In this way the free spectral range (FSR) of the signal is obtained with a frequency mixer and it is transferred to the SMSR booster circuit. Then the signal is led to the ECPS. With correct tuning of the SMSR booster, the SMSR was improved by 5 dB.

Chromatic Dispersion

Moreover, there is another problem related to the chromatic dispersion effect of the optical fiber for the OEO. Overcoming the chromatic dispersion effect on the OEO is not a simple task [22]. There are several factors affecting this phenomenon. These are the operating frequency, the optical length and the modulation technique of the laser. Therefore, there are several issues that should be taken into consideration. One of the solutions is to use advanced modulation techniques, such SSB, QPSK, QAM, etc. In order to have the SSB modulation technique in the OEO, the dual-drive MZM can be used. In

addition there is another possibility to use a laser with a low wavelength. This means that, for instance, if we use a 1310-nm wavelength laser instead of 1550, we have a chance to avoid the chromatic dispersion effect in a standard single-mode fiber (SMF). In addition, another possibility is using a dispersion-shifted fiber instead of SMF.

Rayleigh scattering

Furthermore, to decrease the Rayleigh scattering effect on the OEO, in the literature there are several solutions. One of these solutions is to use an optical fiber with less dopant [23] added (which has 20% less losses than pure silica) to the core of the optical fiber. In addition, a fiber with a lower glass fictive temperature [24], which is a consequence of the thermal history of the glass (mainly related to the drawing stage of fiber production), should be used. It is well known that a fiber with a pure silica core has less Rayleigh-scattering loss than a fiber with a doped silica core. For a reduction of the Rayleigh scattering effect it is also suggested to use phase modulation [25]. In addition, laser frequency modulation [26] is another way to decrease the Rayleigh scattering.

IV. CONCLUSION

As a conclusion, with this paper one of the promising oscillators and its problems and possible solutions in the mm-W range applications were described. This oscillator brings an advantage about the independency of the phase noise from frequency, and means somehow stabilizing the phase noise characteristic over the frequency band. On the other hand, this oscillator has possible challenges to deal with in the mm-W range. The main four expected problems of the OEO in the mm-W range have been defined and possible solutions for them from the literature were explained in this paper. There are different methods/techniques to decrease the effects of these problems, but there is still a big debate about which combination of those methods is the best. This is still a question and the best answer should be known after implementations of all the possible combination of methods and their comparison.

Next-generation 5G wireless and mobile networks are challenging and nowadays there are many ideas being offered. In our opinion, employing the low-phase-noise oscillator in a 5G wireless networks is very important to increase the efficiency; therefore, we propose to use the OEO in the central station of 5G networks instead of using it in each base-station. With this idea, we can feed plenty of base-stations with one oscillator signal from the central station. One of the greatest benefits of this idea is that by using the OEO in the central station, we will have more chance to control and stabilize the oscillator than when using it in the base-station. In addition, we can decrease the cost of the base-station and simplify the base-stations [7].

The effect of the listed problems should be minimized as much as possible to use the OEO properly in various applications, including 5G wireless and mobile networks.

ACKNOWLEDGEMENTS

The authors would like to express their gratitude to the company InLambda BDT d.o.o. for the research equipment and devices. The work presented in this article was created within the FiWIN5G Innovative Training Network, which has received funding from the European Union's Horizon 2020 Research and Innovation Programme 2014–2018 under the Marie Skłodowska-Curie Action grant agreement No.642355.

REFERENCES

- [1] M. A. Ilgaz, and B. Batagelj, "Preliminary idea for a converged fixed and mobile network infrastructure with 5G using Radio-over-Fiber technology and an Opto-Electronic Oscillator in the millimeter-wave range," in *Proc. ICTON 2016*, pp.1-4, Trento, Italy, July 2016, paper Tu.P.5.
- [2] R.T. Logan, L. Maleki, and M. Shadaram, "Stabilization of oscillator phase using a fiber-optic delay-line," in *Proc. 45th Annual Symposium on Frequency Control*, pp. 508-512, May 1991.
- [3] X. S. Yao, and L. Maleki, "Optoelectronic microwave oscillator," *J. Opt. Soc. Am. B* 13, no. 8, pp. 1725–1735, 1996.
- [4] B. Batagelj, L. Bogataj, and M. Vidmar, "Key properties and design issues for an opto-electronic oscillator," in *Proc. ICTON 2015*, pp.1-4, Budapest, Hungary, July 2015, paper Mo.C5.4.
- [5] K.Mikitchuk, A.Chizh, and S.Malyshv, "Theoretical Investigation of External Influences on Delay-Line Optoelectronic Oscillator," in *MWP 2015*, pp.1-4, Paphos, Cyprus, Oct. 2015.
- [6] P.Zhou, S.Pan, D.Zhu, R.Guo, F.Zhang, and Y.Zhao, "A Compact Optoelectronic Oscillator Based on an Electroabsorption Modulated Laser," *IEEE Photonics Technology Letters*, vol. 26, no.1, pp.86-88, Jan.2014.
- [7] M.A.Ilgaz, and B.Batagelj, "Proposal for the distribution of a low-phase-noise oscillator signal in the forthcoming fifth-generation mobile network by radio-over-fibre technology," in *ELMAR 2016*, pp.13-16, Zadar, Croatia, Sep. 2016.
- [8] M.Benisha, R.T. Prabu, and V.T. Bai, "Requirements and Challenges of 5G Cellular Systems," in *AEEICB*, pp.251-254, Chennai, India, Feb. 2016.
- [9] A. Docherty, C. R. Menyuk, J. P. Cahill, O. Okusaga, and W. Zhou, "Rayleigh-Scattering-Induced RIN and Amplitude-to-Phase Conversion as a Source of Length-Dependent Phase Noise in OEOs," *IEEE Photonics Journal*, vol.5, no.2, Apr. 2013.
- [10] K.Mikitchuk, A.Chizh, and S.Malyshv, "Modeling and Design of Delay-Line Optoelectronic Oscillators," *Journal of Quantum Electronics*, vol.52, no.10, Oct. 2016.
- [11] T. Berceci, E. Udvary, and A. Hilt, "A new equalization method for dispersion effects in optical links," in *ICTON 2008*, pp. 98-101, Athens, Greece, June 2008.
- [12] G. H. Smith, D. Novak, and Z. Ahmed, "Overcoming chromatic-dispersion effects in fiber-wireless systems incorporating external modulators," *IEEE Trans. Microw. Theory Techn.*, vol. 45, no. 8, pp. 1410-1415, Aug 1997.
- [13] H. Schmuck, "Comparison of optical millimeter-wave system concepts with regard to chromatic dispersion," *Electron. Lett.*, vol. 31, no. 21, pp. 1848–1849, Oct. 1995.
- [14] A. Docherty, C. R. Menyuk, O. Okusaga, and W. Zhou, "Stimulated Rayleigh scattering and amplitude-to-phase conversion as a source of length-dependent phase noise in OEOs," in *Frequency Control Symposium 2012*, Maryland, USA, May 2012.
- [15] K.Mikitchuk, A.Chizh, and S.Malyshv, "Delay-Line Optoelectronic Oscillator with All-Optical Gain," in *EuMC 2016*, pp. 953-956, London, United Kingdom, Oct. 2016.
- [16] L. Bogataj, M. Vidmar, and B. Batagelj, "A feedback control loop for frequency stabilization in an opto-electronic oscillator," *J. Lightwave Technol.*, vol. 32, no. 20, pp. 3690-3694, Oct. 2014.
- [17] M. Bagnell, J. Davila-Rodriguez, and P.J. Delfyett, "Millimeter-wave generation in an optoelectronic oscillator using an ultrahigh finesse etalon as a photonic filter," *J. Lightwave Technol.*, vol. 32, no. 6, pp. 1063-1067, Mar. 2014.
- [18] J.-H. Cho, H. Kim, and H.-K. Sung, "Reduction of Spurious Tones and Phase Noise in Dual-Loop OEO by Loop-Gain Control," *IEEE Photonics Technology Letters*, Vol. 27, no.13, pp. 1391-1393, July 2015.
- [19] E. Shumakher, and G. Eisenstein, "A novel multiloop optoelectronic oscillator," *IEEE Photonics Technol. Lett.*, vol. 20, no. 22, pp. 1881–1883, Nov. 2008.
- [20] L. Bogataj, M. Vidmar, and B. Batagelj, "Opto-electronic oscillator with quality multiplier," *IEEE Trans. Microw. Theory Techn.*, vol. 64, no. 2, pp. 663-668, Feb. 2016.
- [21] L. Bogataj, M. Vidmar, and B. Batagelj, "Improving the side-mode suppression ratio and reducing the frequency drift in an opto-electronic oscillator with a feedback control loop and additional phase modulation," *J. Lightwave Technol.*, vol. 34, no. 3, pp. 885-890, Feb. 2016.
- [22] G. H. Smith, D. Novak, and Z. Ahmed, "Overcoming Chromatic Dispersion Effects in Fiber-Wireless Systems Incorporating External Modulator," *IEEE Trans. on Mic. Theory and Techn.*, vol. 45, no. 8, pp.1410-1415, 1997.
- [23] K. Tajima, M. Ohashi, K. Shiraki, M. Tateda, and S.Shibata, "Low Rayleigh Scattering P2O5-F-SiO2 Glasses," *J. Lightwave Technol.*, vol.10, no.11, pp. 1532-1535, Nov.1992.
- [24] K. Tsujikawa, K. Tajima, and M. Ohashi, "Rayleigh Scattering Reduction Method for Silica-Based Optical Fiber," *J. Lightwave Technol.*, vol.18, no.11, pp.1528-1532, Nov.2000.
- [25] A. Yariv, H. Blauvelt, and S.-W. Wu, "A reduction of interferometric phase-to-intensity conversion noise in fiber links by large index phase modulation of the optical beam," *J. Lightwave Technol.*, vol. 10, no. 7, pp. 978–981, July 1992.
- [26] D. Eliyahu, D. Seidel, and L. Maleki, "RF amplitude and phase-noise reduction of an optical link and an opto-electronic oscillator," *IEEE Trans. Microwave Theory Tech.*, vol. 56, no. 2, pp. 449–456, Feb. 2008.